

EVB9351AUT KD9351+KD1053 Eval-Board

1000BASE-RHC Automotive Bridge

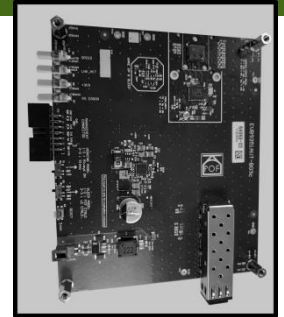

KD1050 FAMILY - Automotive



OVERVIEW

The KDPOF EVB9351AUT is a board for a comprehensive evaluation of the KDPOF KD9351 and KD1053 transceivers for automotive optical 1000BASE-RHC PHY implementation. The KD9351 IC (7 mm x 8 mm LGA-36) implements the PMD sublayer of the physical layer; while the KD1053 (7 mm x 7 mm QFN-56), the PCS and PMA sublayers as defined in IEEE Std 802.3bvTM-2017. It can operate at 1000 and 100 Mbps. The board hosts an SFP slot and it may function as media converter between the optical optical 1000BASE-RHC port and the SFP-module (1000/100BASE-T, 100BASE-FX, 1000BASE-S/LX, direct-attach passive twinax cable, passive serial loopback...).

The EVB9351AUT platform provides all the functional and performance evaluation capabilities requested by the automotive OEM, TIER-1 or test house, enabling product designers to successfully evaluate KDPOF's technology and to shorten the time to market. The board may be used in different setups such as to evaluate the KD1053. Design documentation as well as SDK software is provided together with the board.

KEY FEATURES

- One-gigabit full-duplex operation according to the 1000BASE-RHC physical layer (IEEE Std 802.3bvTM-2017) and hundred-megabit full-duplex operation according to the future 100BASE-H physical layer
- Operates at 1 Gbps with 15 m with up to three in-line connectors¹; and at 100 Mbps 40 m with up to four in-liners
- This board is compatible with diverse optical header connectors available in the market
- Support for SGMII, 1000BASE-X and 100BASE-X at the SFP interface
- RGMII loopback implemented
- Easy monitoring and configuration of the KD1053 through the management header (for the USB2ALL)
- Guaranteed 10^{-12} BER according to RFC 2544
- Wake-Up & Sleep supported
- Single power supply from battery voltage
- Operation temperature range from -40 to 105°C

MAJOR BENEFITS

- Ideal platform to test the functionality and the performance of KD9351 and KD1053 transceivers at 1000/100 Mbps.
- Designed for thermal testing in the whole temperature range.
- Power connectors are automotive specific; cables are thought to be connected to a laboratory power supply or battery.
- The USB2All module enables real-time monitoring of the optical link, reporting key performance parameters (received average optical power (dBm), local and remote link margin (dB)) and configuration. Register access is supported.
- Documentation and SDK included.

CONFIGURATION

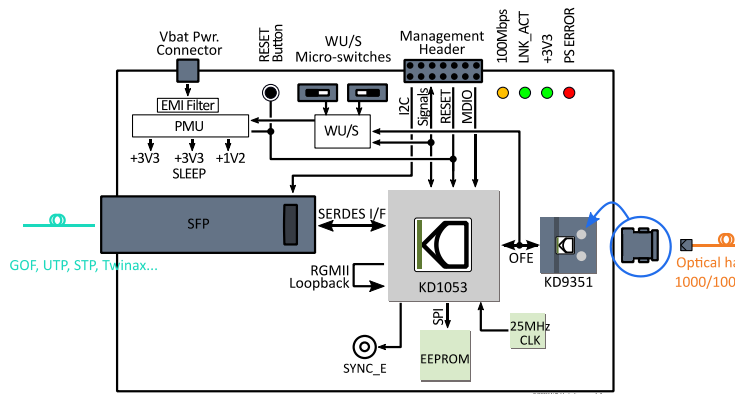

Figure 1. Block diagram of EVB9351AUT

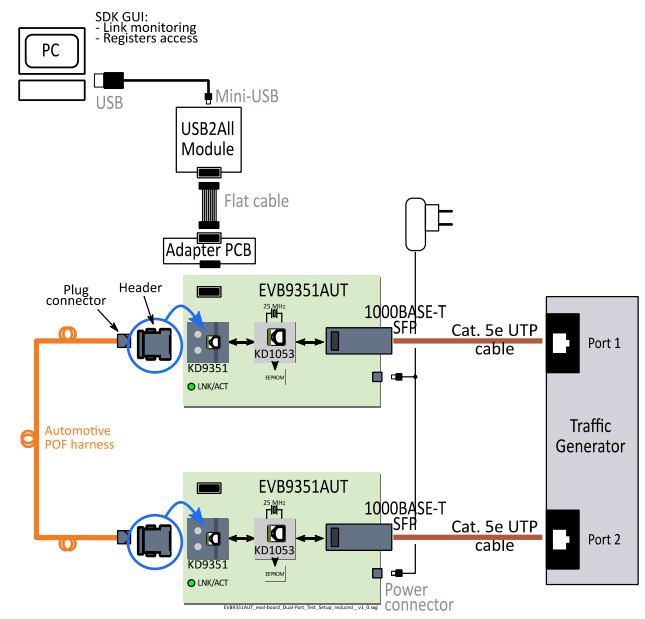

Figure 2. Typical traffic test setup for EVB9351AUT

¹ More in-line connectors can be added for ambient temperatures below 105°C.

Product Brochure

EVB9351AUT KD9351+KD1053 Eval-Board

PRODUCT DESCRIPTION

The KDPOF EVB9351AUT eval-board is a flexible tool that enables evaluation of the KDPOF KD9351 and KD1053 transceivers at 1 Gbps and 100 Mbps. A single version of the board is compatible with multiple headers and harnesses from different manufacturers.

The user can plug a standard SFP module into the cage and have a media-converter functionality, supporting Wake-Up & Sleep.

Complementary items can be provided, such as optical harness, loopback SFP or SFP direct-attach passive twinax cable.

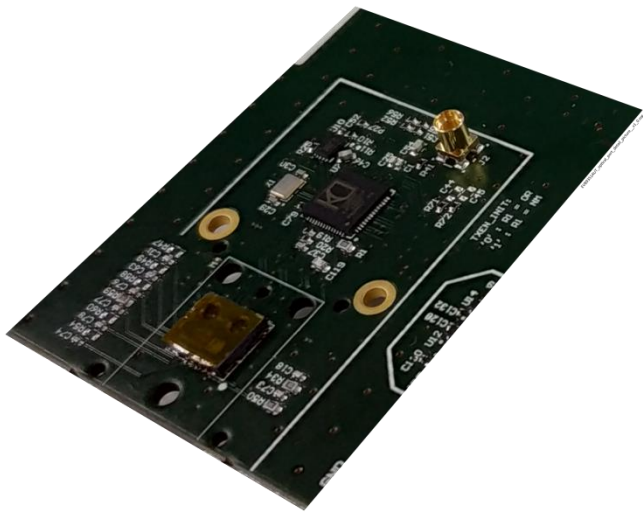

Figure 3. Detail of the optical port in the EVB9351AUT board

The configuration of the board is in an EEPROM memory. The provided SDK allows generating binaries for different configuration options and flashing the EEPROM.

In addition, control and status of the KD1053 transceiver is accessed through the GUI (included in the SDK), which may be run on a computer connected via an USB2All module. The GUI includes several panels that provide complete access to the KDPOF transceiver, providing information on the link status and its parameters.

User and design documentation is provided in order to simplify the evaluation and the development of automotive end products based on the two part numbers.



Figure 4. Typical content of an EVK9351AUT eval-kit



KDPOF
Ronda del Poniente 14, 2-CD
28760 Tres Cantos (Madrid)
Spain
Tel: +34 918043387 • Fax: +34 918063725
www.kdpof.com
BR026 v1.2 | March 2021
© 2021 KDPOF. Specifications can be changed without notice.